

PLANVIEW
N.T.S.

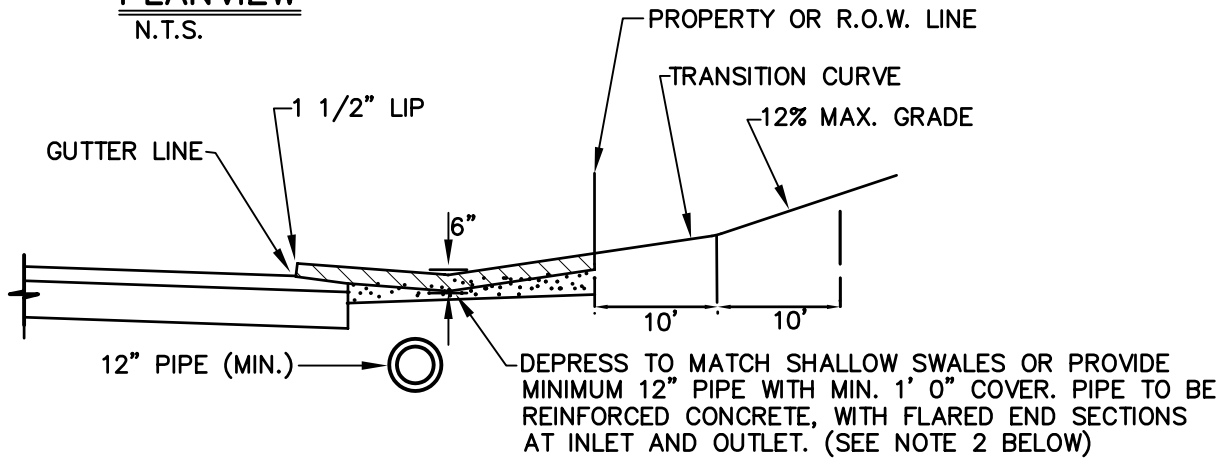

SECTION - UPHILL DRIVEWAY
N.T.S.

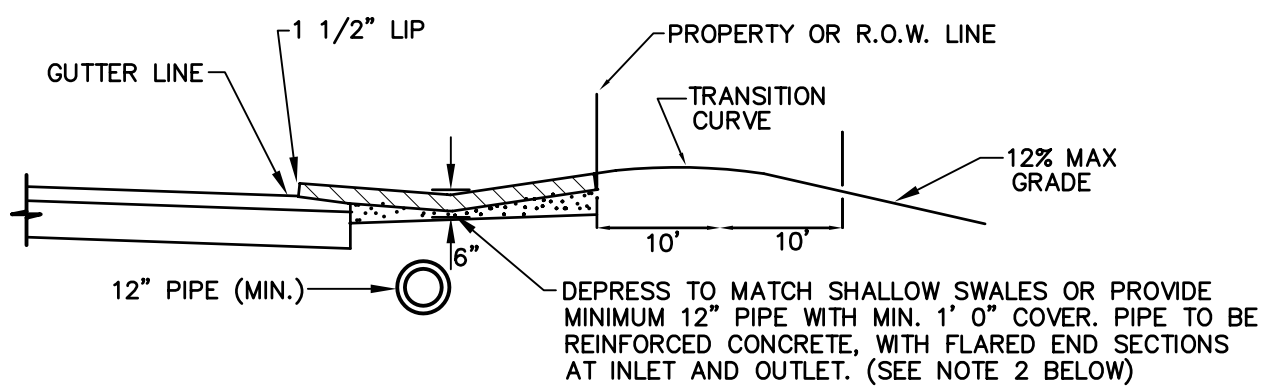

SECTION - DOWNHILL DRIVEWAY

NOTES:

1. IF ROADWAY CROSS SECTION DOES NOT INCLUDE OFF ROAD SWALE, DRIVEWAY APRON SHALL BE AS REQUIRED FOR CURBED ROADWAY.
2. DRIVEWAY CULVERTS SHALL BE REQUIRED BASED ON FIELD CONDITIONS AND AS APPROVED BY THE TOWN ENGINEER AND DIRECTOR OF PUBLIC WORKS.

STANDARD DETAIL DRAWING
RESIDENTIAL DRIVEWAY DETAIL
ROADWAY WITH OPEN DRAINAGE

HEBRON
PUBLIC IMPROVEMENT
SPECIFICATIONS

REVISIONS:

SCALE: NONE

DATE: OCTOBER, 2001 PLATE 11